



PLUMPTON HIGH SCHOOL

Artwork By Student:
Lilith Dartnell



SUBJECT SELECTION

2026

STAGE

5



Subject Consumable Fees

While many of the courses offered at our school come with no cost, some subjects use a significant amount of consumable resources and as such incur a consumable fee. The subject selection handbook and associated individual course information clearly identify whether a course incurs a consumable fee, allowing you to make informed decisions.

To support the delivery of these courses, parents are required to cover the associated consumable costs. Once your child has completed the online subject selection process, please bring either a printed copy or a screenshot of their selected subjects to the front office. To secure a place in any subject that incurs a fee, payment of the main units consumable fee must be made at the front office by **26 September 2025**.

Please note that subject fees cannot be paid online.

This process is essential for us to accurately gauge student interest, allowing us to create the appropriate number of classes and ensure we have the necessary resources to commence teaching and learning from day one of the new school year.

We understand that there may be times when a student does not receive a requested subject, even after payment. In such cases, please rest assured that any fees paid will be refunded in due course.

Thank you for your cooperation and support as we work together to provide a meaningful educational experience for all our students. If you have any questions or concerns regarding the subject selection process, please do not hesitate to contact the school office.

TABLE OF CONTENTS

INTRODUCTION	4
STAGE 5 ROSA REQUIREMENTS.....	5
ENGLISH	7
SCIENCE.....	7
MATHEMATICS.....	8
PERSONAL DEVELOPMENT, HEALTH & PHYSICAL EDUCATION	9
GEOGRAPHY.....	10
HISTORY	10
AGRICULTURAL TECHNOLOGY FEE: \$25	12
CHINESE FEE: NIL.....	13
COMMERCE FEE: NIL	14
COMPUTING TECHNOLOGY FEE: NIL.....	15
DANCE FEE: \$12	16
DRAMA FEE: \$12	17
FOOD TECHNOLOGY FEE: \$80	18
GRAPHICS TECHNOLOGY (CAD) FEE: \$25	19
HISTORY ELECTIVE FEE: NIL.....	20
INDUSTRIAL TECHNOLOGY – ENGINEERING FEE: \$80.....	21
INDUSTRIAL TECHNOLOGY – METAL FEE: \$80	22
INDUSTRIAL TECHNOLOGY – TIMBER FEE: \$80.....	23
LADY TRADIES FEE: \$80	24
MUSIC FEE: \$30.....	25
MUSIC THEATRE FEE: \$20	26
PHOTOGRAPHIC AND DIGITAL MEDIA FEE: \$35.....	27
PHYSICAL ACTIVITY AND SPORTS STUDIES FEE: NIL.....	28
VISUAL ARTS FEE: \$40.....	29
VISUAL DESIGN FEE: \$35.....	30

INTRODUCTION

The subject selection process is a very important decision time for students and parents when preparing for Years 9 and 10. This booklet and the subject selection presentation are key tools to assist you to successfully navigate this process.

This handbook has been developed to provide a summary of the courses that are available at Plumpton High School in 2026-2027 for Years 9 and 10 and to support students and parents preparing for entry into Stage 5.

Current Year 8 students will use the information in this booklet to make informed choices about their Stage 5 pattern of study. Years 9 and 10 together constitute the Stage 5 course. Grades from all subjects studied over the two years are submitted to NESA for the awarding of the Record of School Achievement (RoSA) credential. This credential is a prerequisite for the commencement of the Year 11 Preliminary HSC course, the first year of Stage 6 studies.

It is important for students to give their elective choices careful consideration. Students should select subjects they enjoy, as this will provide them with a positive attitude towards learning and develop the essential study skills and motivation required for success in the important Years of 11 and 12. Students should focus on selecting subjects that interest them, not what their friends are doing and not on the teacher who may take the class. Parents and students must note that students do not need to limit their elective choices in Stage 5 to areas they think they may wish to pursue in senior years. No subjects in Years 11 and 12 have a prerequisite in the junior school.

Parents, please read the information contained in this handbook carefully, so that you may be in a position to guide your child in the selection of the elective subjects. If any parents have questions please contact the school on 9625 7020 or email Priyanka Karan: priyanka.karan3@det.nsw.edu.au.

The commencement of Stage 5 is an exciting time for students. They are offered new challenges and have real choices in terms of the curriculum they study. I would like to take this opportunity to wish each student well for their studies in Stage 5 and implore each student to commit themselves to their studies and enjoy the curriculum pattern they choose.



Tim Lloyd
Principal

STAGE 5 RoSA REQUIREMENTS

In 2012, the New South Wales Record of School Achievement (RoSA) replaced the School Certificate. Eligible students who leave school prior to receiving their Higher School Certificate will receive the RoSA. NESA has developed information for teachers, students and parents on how the RoSA will be implemented. (See link:

<http://educationstandards.nsw.edu.au/wps/portal/nesa/11-12/leaving-school/record-of-school-achievement>

In line with the RoSA the school ensures that each student studies a pattern of courses which meets NESA's requirements. To meet academic requirements students in Stage 5 must:

- **Follow** the course developed or endorsed by NESA.
- **Apply** themselves with diligence and sustained effort to the set course work, tasks and experiences provided in the course by the school including homework.
- **Achieve** some or all of the course outcomes as demonstrated in assessment tasks, practical requirements and assigned work.
- **Maintain** a satisfactory level of class attendance. A student whose attendance affects their ability to demonstrate understanding of course outcomes is at risk of an N-determination. Students are responsible for explaining their absences to each teacher.

If attendance is less than 95% of available school time then a student will have difficulty achieving a reasonable range of outcomes for each course being studied. Where a student's attendance and/or effort are in question or obviously unsatisfactory, parents will be notified.

Pattern of Study

Students are required to study the following subjects:

Mandatory: English, Mathematics, Science, Personal Development, Health and Physical Education (PDHPE), History and Geography.

Electives: Each student is also required to study at least 2 elective subjects during Years 9 & 10. 200 hour courses run for two years, 100 hour courses run for one year.

There are three possible patterns of study for electives:

Pattern 1: TWO 200 hour courses

Pattern 2: ONE 200 hour course and TWO 100 hour courses

Pattern 3: FOUR 100 hour courses

Students will have an opportunity to select new elective subjects in Year 10 as required.

SPECIAL COURSE REQUIREMENTS

- Some subjects involve costs for materials and or excursions. Students who select such courses will be expected to meet these expenses in the usual system of payments and are expected to attend excursions.
- Some subjects have special requirements. For example, to supply and wear an apron, or special footwear. Students who select these courses will be expected to meet these requirements.

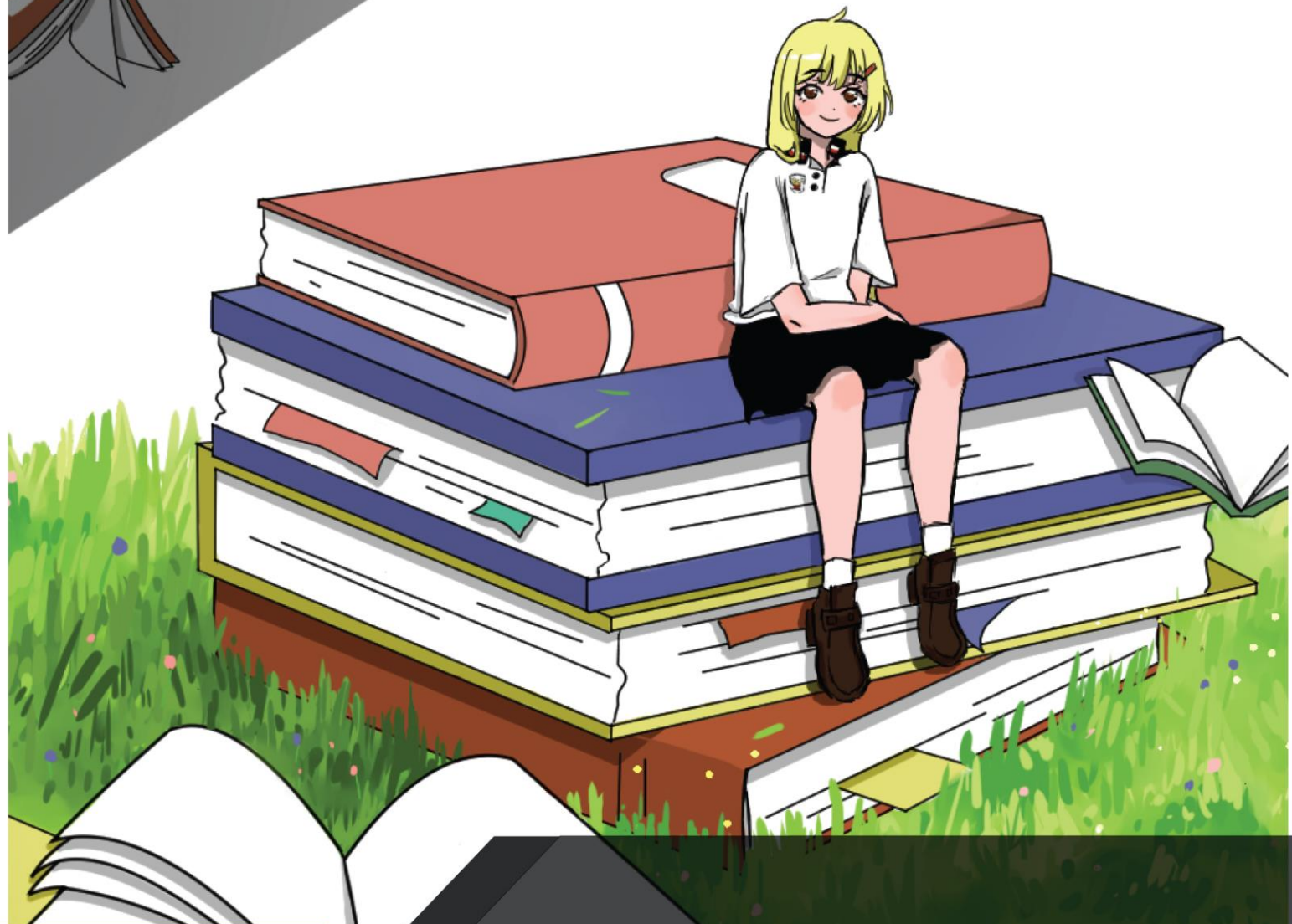

MANDATORY COURSES

ENGLISH

The aim of English in the junior school is to enable students to strive towards personal excellence in using language to shape meaning so that they are able to communicate effectively with those around them in their personal, school and work lives.

Through responding to and composing a wide range of texts and through the close study of texts, students will develop knowledge, understanding and skills in order to:

- communicate through speaking, listening, reading, writing, viewing and representing
- use language to shape and make meaning according to purpose, audience and context
- think in ways that are imaginative, creative, interpretive and critical
- express themselves and their relationships with others and their world
- learn and reflect on their learning through their study of English

Students will focus on the following areas:

- Discursive, Imaginative, Persuasive, Informative and multimodal texts and compositions
- Personal reflections on their own composition and learning process
- Analytical essays, using the ALARM (A learning and responding matrix) process
- Exam techniques, timed writing and organisational skills

It is essential that parents and students recognise that students' skills will be assessed at a national level during the National Assessment Program for Literacy and Numeracy (NAPLAN) in Year 9. Additionally, in year 10 all students will sit their Reading and Writing Minimum Standards Tests and will be required to achieve a level 3 in order to achieve their Higher School Certificate in Stage 6. Students will have numerous attempts to take this test and it is imperative that they accept all support offered to them.

SCIENCE

The study of Science in Years 9 & 10 develops students' scientific knowledge and understanding, skills, values and attitudes within broad areas of Science that encompass the traditional disciplines of Physics, Chemistry, Biology and the Earth Sciences. As well as acquiring scientific knowledge and skills, students apply their understanding to everyday life and develop an appreciation of science as a human activity. Students learn about the need to protect, conserve and maintain the environment, the use and importance of technology in advancing science, and the role of science in developing technology. Students also develop an appreciation of, and skills in, selecting and using resources and systems to solve problems.

The Science course is practically based and 60% of their time is spent in conducting practical work. This could include: experimental work, fieldwork, use of computer simulations, and research using multimedia and the Internet. During practical work, students will learn to plan and conduct investigations, communicate information, develop scientific thinking, solve problems and work individually and in teams. Students will participate in an individual Student Research Project that will involve "hands on" practical investigation of the student's choice.

The Science course offered in Years 9 and 10 at Plumpton High School is also an excellent preparation for students intending to study Science courses (Physics, Chemistry, Biology, Earth and Environmental Science, Investigating Science, Agriculture or Primary Industries) at the HSC level.

MATHEMATICS

Mathematical ideas have evolved and continue to develop across cultures and have been practised in Australia by Aboriginal and Torres Strait Islander Peoples for thousands of years. Through the study of mathematics, students apply their knowledge and skills to deepen their understanding of the world. Mathematics is a reasoning and creative activity, integral to scientific and technological advances across many fields of endeavour. The symbolic nature of mathematics provides a powerful and precise means of communication.

Making connections across mathematical concepts and other subject areas enhances students' ability to understand the purpose of learning mathematics and to develop a deeper conceptual understanding. This helps students to recognise the role of mathematics in solving problems in the world around them, applying their understanding to familiar and unfamiliar situations.

By studying mathematics, students develop essential numeracy skills and fluency, while nurturing the ability to think logically, critically and creatively. They learn about patterns and reason about relationships, creating opportunities to generalise their solutions and to solve non-routine problems.

When students enjoy learning mathematics, they develop a positive self-concept and become self-motivated learners through active participation in appropriately challenging tasks. This can enhance their resilience in solving mathematical problems relevant to further education and their everyday lives.

9–10 Core–Paths structure

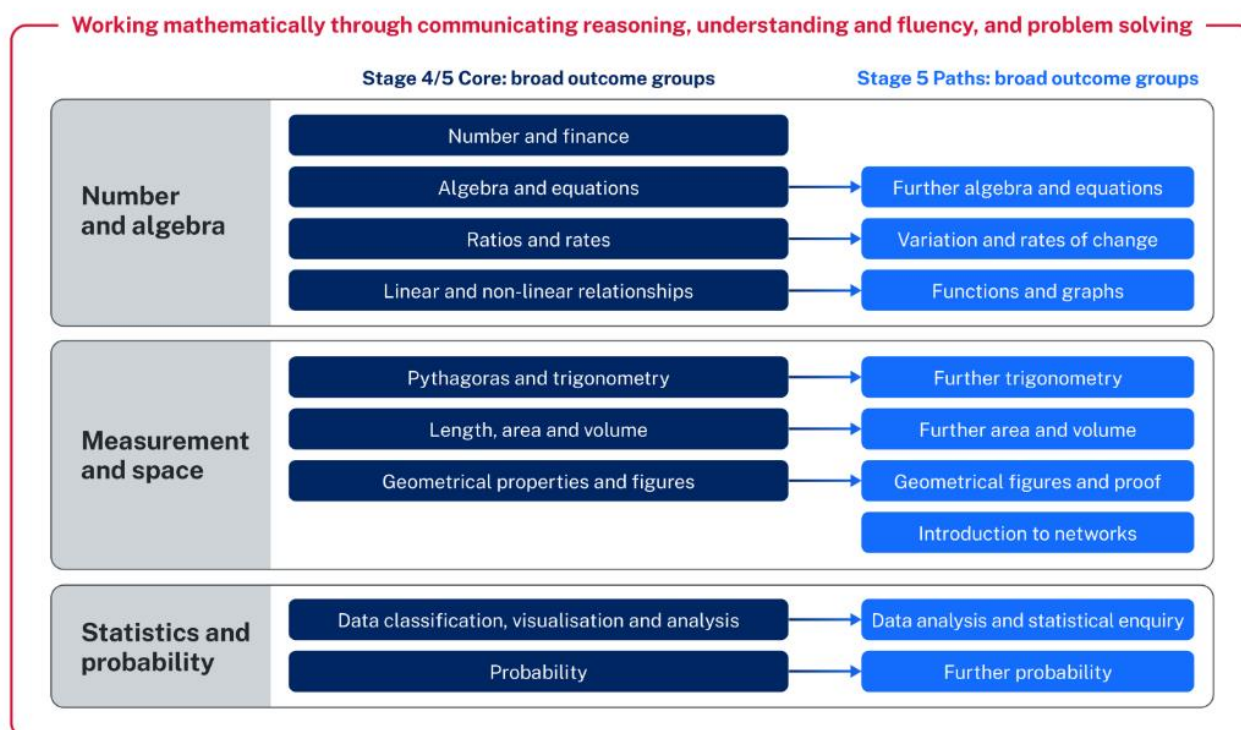

The Core–Paths structure is designed to encourage aspiration in students and provide the flexibility needed to enable teachers to create pathways for students working towards Stage 6. The structure is intended to extend students as far along the continuum of learning as possible and provide solid foundations for the highest levels of student achievement. This structure allows for a diverse range of endpoints up to the end of Stage 5.

The Core outcomes provide students with the foundation for Mathematics Standard 2 in Stage 6. Students who require ongoing support in completing all Stage 5 Core outcomes may consider either Mathematics Standard 1 or the Numeracy CEC course in Stage 6. For these students, teachers continue to extend

students towards demonstrating achievement in as many Stage 5 Core outcomes as possible. This is to enable as many students as possible to have the knowledge and skills necessary to engage in the highest level of mathematics possible.

The aim for most students is to demonstrate achievement of the Core and as many Path outcomes as possible by the end of Stage 5 and this should guide teacher planning. Allowing time for students to demonstrate understanding of the Core outcomes will be a key consideration in Years 9 and 10.

Typically, the Core will cover teaching and learning experiences up to the middle of Stage 5. It is not the intention of the Core–Paths structure to lock students into predetermined pathways at the end of Stage 4. Pathways offered in Stage 5 will be carefully planned to ensure some students have the opportunity to engage with Advanced and Extension courses.

Paths are used to progress students towards Stage 6 courses and may be implemented at any time in Stages 4 and 5 with careful consideration of the continuum of learning. Teachers also have the option of engaging with specific elements of Paths rather than the entire outcome to meet the needs of their students. Mathematics Teachers will plan to cover as many Paths as practicable. It is also important that students and parents are aware that the assessment and examination results from Year 8 will be used to place students into the appropriate core-paths pathways for Year 9. All students are expected to have **Calculators** for Mathematics.

All students in Year 10 will need to sit minimum standards testing for numeracy and literacy and achieve at least a Level 3 in each of the online tests to meet the HSC Minimum Standard.

PERSONAL DEVELOPMENT, HEALTH & PHYSICAL EDUCATION

Personal Development, Health and Physical Education (PDHPE) develops the knowledge, understanding, skills and attitudes important for students to take positive action to protect and enhance their own and others' health, safety and wellbeing. Physical education is fundamental to the acquisition of movement skills and concepts to enable students to participate in a range of physical activities – confidently, competently and creatively.

PDHPE provides students with the opportunity to enhance and develop resilience and connectedness and learn to interact respectfully with others. Through PDHPE students develop the skills to research, apply, appraise and critically analyse health and movement concepts in order to maintain and improve their health, safety, wellbeing and participation in physical activity. Students develop a commitment to the qualities and characteristics that promote and develop empathy, resilience, respectful relationships, inclusivity and social justice. Students practise, develop and refine the physical, cognitive, social and emotional skills that are important for engaging in movement and leading a healthy, safe and physically active life.

Learning in PDHPE reflects the dynamic nature of health, safety, wellbeing and participation in physical activity in the context of a diverse and rapidly changing society. It addresses health and physical activity concepts of importance to students and highlights the influences that contextual factors have on personal values, attitudes and behaviours. Through PDHPE, students develop self-management, interpersonal and movement skills to help them become empowered, self-confident and socially responsible citizens. The learning experiences in PDHPE provide students with a foundation to actively contribute to, and advocate for, the health, safety and wellbeing of themselves and others in the community and beyond school.

Year 9 PDHPE – 2 theory lessons, 3 practical lessons, 1 Duke of Edinburgh lesson per fortnight.

Year 10 PDHPE – 2 theory lessons, 3 practical lessons per fortnight.

GEOGRAPHY

Throughout Stage 5 this course focuses on Australia, its character and place in the world and the Asia - Pacific region. This includes:

- Australia's Physical Environments
- Changing Australian Communities
- Issues in Australian Environments
- Australia in Its Regional and Global Contexts.

Throughout this course students will develop skills in reading maps, understanding climate change and interpreting different perspectives. The ultimate outcome of such a study will be to provide each student with the capacity to enjoy their world.

The skills learned in Geography are valuable life skills which will assist in everyday challenges and vocational opportunities. Case studies are drawn, where possible, from the students' local area, Australia and the globe. Various fieldwork and excursion opportunities exist, which relate the theory of the classroom to the realities of the world.

HISTORY

Throughout Stage 5 this course focuses on Australian History since the arrival of the first fleet to the modern day. Students explore:

- Australia's Involvement in World War I and II
- The Stolen Generations and Reconciliation
- Women in Australian History, Citizenship and Migrant Australians
- Many other topics which affected Australians during the 20th Century.

Throughout this course students will develop skills in understanding of Australia's international relationships, analysing and critiquing sources and communicating their understanding of history.

History is about investigation, thinking and communication. You are taught how to find out information, how to engage in thinking about the past and how to communicate your ideas. An understanding of the past is necessary in order to be an informed and active citizen of the future.

Historians cannot just stick to books. They must use databases, debates, field trips, archaeology and any other available techniques to uncover the facts about the past. History lessons will provide both variety and challenge, as critical thinking is at the forefront of this subject.

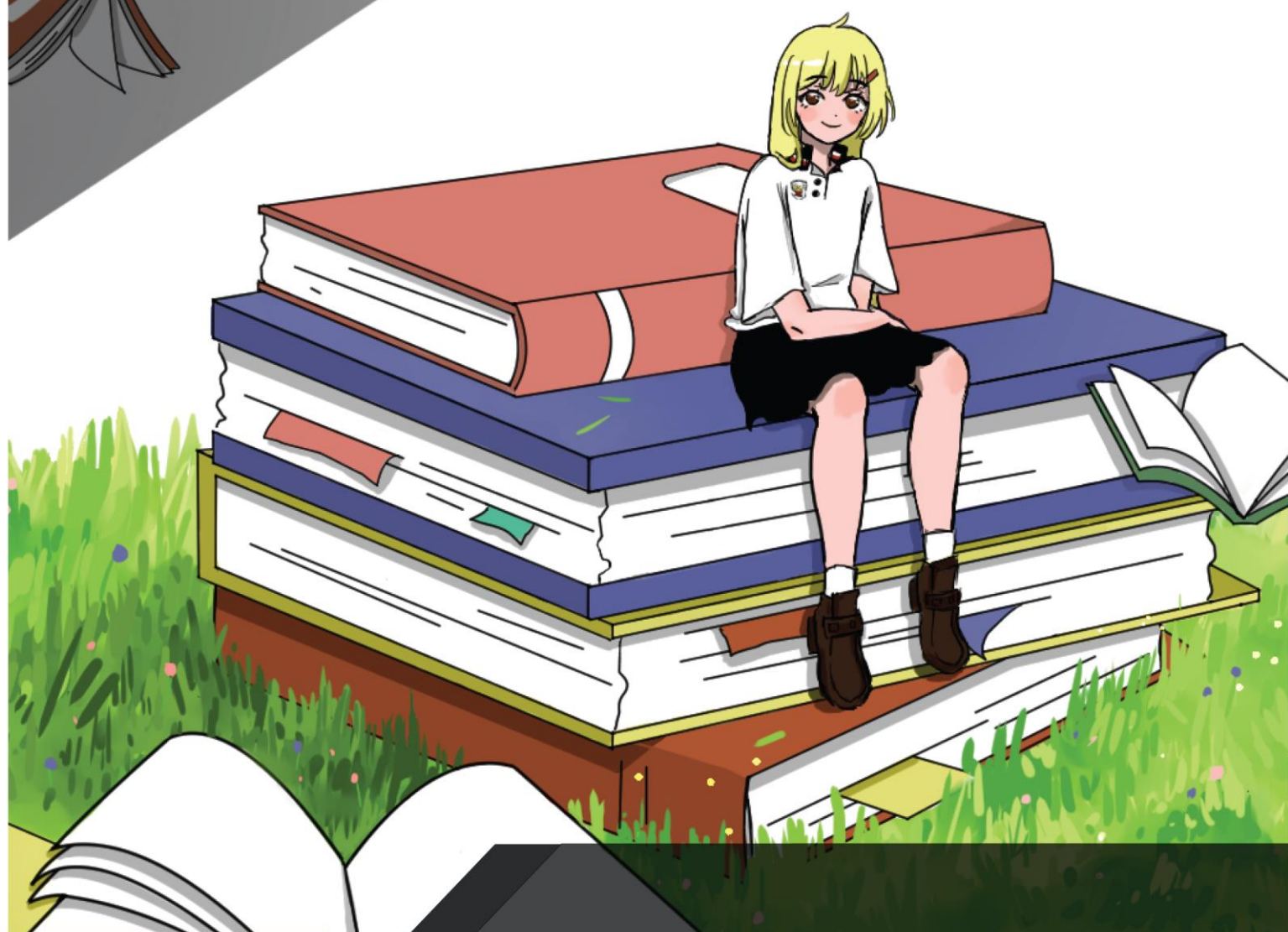

ELECTIVE COURSES

Course Description

Agriculture is the study of farming to produce usable products for human society. The agricultural sector in Australia produces almost 9 billion dollars in goods and services and employs approximately 1.6 million people. With the increasing challenges of climate change, soil and resource depletion and the increasing demand for local and sustainable agriculture, there is increasing opportunity for new and innovative processes in agriculture.

The study of agriculture allows students to develop knowledge and understanding, or skills in:

- Animal health and plant requirements
- Problem solving, including collecting, analysing, interpreting and presenting information
- Working safely and cooperatively
- Animal welfare
- Environmental responsibility
- The place of agriculture in the local and global economy
- Social and ethical implications of agriculture
- Production and marketing of animal disease prevention products



200 hours (2 years) or 100 hours (1 year) Course

In both the 100 hour and 200 hour course, students will learn about plants, animals and their interactions with the environment through managing agricultural enterprises and marketing products.

Agricultural enterprises studied are selected from the following (please note that not all of these are studied, this is what could be studied):

- Egg production
- Meat chicken production
- Dairy production
- Aquaculture/ hydroponics
- Large scale cropping such as corn, wheat and rice
- Nursery production
- Orchards / viticulture
- Beef cattle production
- Sustainability and native trees and landscapes



Students are required to wear **leather boots** and a **hat** if they wish to study this course. Students are encouraged to bring sunscreen for practical lessons and may bring a change of clothes for work down at the farm. Students will be expected to change into their change of clothes **before** the commencement of the lesson and be back in full school uniform after the lesson.

Assessment

Students are assessed through a variety of practical activities, reports and experimental presentations.

Course Description

Learning languages provides the opportunity for students to engage with the linguistic and cultural diversity of the world and its peoples. Students broaden their horizons in relation to personal, social, cultural and employment opportunities in an increasingly interconnected and interdependent world. Contemporary research and practice have established a clear link between the learning of languages and improved literacy skills. Chinese is not only the official language of China but also widely spoken throughout Asia, as well as being the foundation for the Korean and Japanese writing systems. Through learning of Chinese, students develop an intercultural capability and an understanding of the role of language and culture in communication, as well as become more accepting of difference and diversity. They develop understanding of global citizenship, and reflect on their own heritage, values, culture and identity

**200 hours (2 years) or 100 hours (1 year) Curriculum**

Students will develop the knowledge, understanding and skills necessary for effective interaction and communication in Chinese. They will listen and respond to Chinese. They will learn to read and respond to written texts in Chinese.

They will explore the nature of languages as systems by making comparisons between English and Chinese.

Students will also develop intercultural understandings by reflecting on similarities and differences between their own and the Chinese culture. They develop a capacity to interact with people, their culture and their language.

Assessment

The language to be studied and assessed is the modern standard version of Chinese.

For the purpose of this syllabus, modern standard Chinese is taken to be *Putonghua* in the spoken form and simplified characters in the written form.



Course Description

Studying Computing Technology enables students to develop skills in the specific application of computing technologies and to develop digital solutions applicable to a range of industrial, commercial and recreational contexts.

Computing Technology focuses on computational, design and systems thinking. It also develops data analysis and programming (coding) skills. The knowledge and skills developed in the course enable students to contribute to an increasingly technology-focused world.

Students have opportunities to develop skills in analysing data, designing for user experience, connecting people and systems, developing websites and apps, building mechatronic systems, and creating simulations or games. Students use hardware and software to manage and secure data. They also investigate the social, ethical and legal responsibilities of using data as creators of digital solutions while considering privacy and cybersecurity principles.



100 hours (1 year) Course

Students undertaking the 100-hour course are required to complete:

- at least one Enterprise Information Systems focus area
- at least one Software Development focus area
- 2–3 focus areas either individually or combined.
- practical learning and project work for most of the course time
- at least one group project

200 hours (2 years) Course

Students undertaking the 200-hour course are required to complete:

- at least 2 Enterprise Information Systems focus areas
- at least 2 Software Development focus areas
- 4–6 focus areas either individually or combined
- practical learning and project work for most of the course time
- at least one group project

Assessment

Students are assessed through a variety of practical activities, research reports and Digital Solutions.

Course Description

Dance appeals to students who are creative. Dance can take a student anywhere - teaching, performing, administration, choreography. You do not have to be stuck behind a desk to use your brain. Dance challenges students to move, create and use their imagination. Students wishing to do their HSC in the future should consider the Dance Course over 200 hours. Students with a general interest should take the 100-hour course.

In this course students will develop the following skills:

- Higher order thinking
- Problem solving
- Creativity
- Critical thinking
- Communication
- Teamwork
- Leadership



200 hours (2 years) or 100 hours (1 year) Course

CREATING YOUR OWN DANCES

This comprises most of the course and allows you to create your own new steps and dances.

DANCE TECHNIQUE

Helps you develop your ability, flexibility, coordination, strength, health and fitness.

STYLES

The syllabus is based on classical modern technique, but students may experience a range of styles of dance including:

- Hip Hop
- Jazz
- Musical Theatre
- Circus/Acrobatics

PERFORMANCE

Opportunities to perform include at:

- Dance festivals
- State and regional School Spectaculars
- School productions
- School assemblies

Assessment

- This course is 70% practical and 30% theoretical.
- Performance of dance works in groups and as solo
- Composing dance which is performed in front of the class and teachers in small groups
- Written extended response – Watching and writing about own and others’ dance performances
- Historical study of dance styles



Course Description

Drama appeals to students who are creative. Drama can take you anywhere – acting, directing, designing costumes, camera technique, teaching, performing administration. Students serious about Drama or who intend to study Drama as an HSC subject should take the Drama Course over 200 hours. Students with a general interest should take the 100 hour course.

In this course students will develop the following skills:

- Higher order thinking
- Problem solving
- Creativity
- Communication
- Team work
- Leadership

**200 hours (2 years) or 100 hours (1 year) Course****ACTING TECHNIQUE**

Learn about improvisation, act out scripted plays and create your own.

BE A PART OF A STAGE CREW

Learn about lighting and sound. Be part of the crew to put on a major production. Be a director. Design costumes and sets

STYLES OF THEATRE

Learn about

- Masks
- Street theatre
- Absurd theatre
- Dada
- Theatre history
- Circus skills

PERFORMANCE

Opportunities to perform include

- State and regional drama camps
- School productions
- State and Regional performances and ensembles
- School ensembles
- GAT drama

**Assessment**

- This course is 70% practical and 30% theoretical
- Group Devised Projects – playbuilding
- Improvisation to develop performance skills
- Working with scripted and unscripted materials to create performance
- Written extended responses- reflection of own work and work of others
- Historical study of theatrical styles and traditions

Course Description

The Australian Food Industry is growing in importance, providing numerous employment opportunities and increasing the relevance of food technology for the individual and society. This course aims to prepare students for a future within the food and hospitality industry by providing them with both theoretical learning and practical experiences. The practical experiences include food preparation, experimental work and excursions to food industries. It involves students investigating food through practical hands on applications and processes.

The Food Technology Syllabus takes into account the diverse needs of all students. It identifies essential knowledge, understanding, skills, values and attitudes and involves students investigating food through practical experience and processes such as research, making and management.

Course Requirements:

- Apron
- Hat
- Shoes [leather upper]
- Tea towel
- Dish cloth
- Container
- Display folder



200 hours (2 years) or 100 hours (1 year) Course



In Food Technology elective course students will focus on the following areas of study:

- Food in Australia
- Food selection and health
- Food for special needs
- Food product development

Core 1: Food Preparation & Processing
Core 2: Nutrition & Consumption.

Assessment

This course is assessed through a range of practical cooking activities as well as written reports and presentations.

GRAPHICS TECHNOLOGY (CAD)

Fee: \$25

Course Description

Computer Aided Drawing is commonplace in today's Manufacturing and Construction Industry. This course is heavily computer orientated with students using Industry Standard Software packages to develop and complete a large variety of CAD projects.

The study of GRAPHICS TECHNOLOGY enables students:

- to become more technically literate
- develop and use logical thought processes
- develop technical and computer drawing skills
- gain experience in computer generated graphics
- gain exposure to industry practices and standards

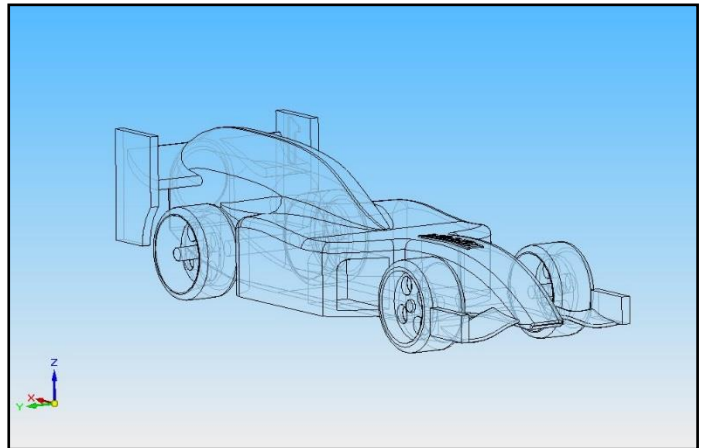

100 hours (1 year) Course

In the 100 Hour course students will gain basic drawing skills, knowledge and attitudes in all areas of technical drawing and computer aided drawing

- Pictorial drawing
- Orthogonal projection
- Architecture
- Rendering
- Geometric construction



200 hours (2 years) Course

In the 200 Hour course students will further develop skills in electives such as:

- Australian Architecture
- Cabinet and Furniture Drawing
- Computer Aided Design & Drawing (CAD)
- Computer Animation
- Engineering Drawing
- Graphic Design
- Landscape Drawing
- Product Illustration
- Technical Illustration
- Student Negotiated Project

Assessment

Student are assessed through the presentation of drawing portfolios and a report.

Course Description

The Elective History course is designed for those students who not only developed an interest in history during Year 7 and 8, but also for students who have a passion or ‘insatiable appetite’ to learn about and interpret events that have shaped the modern and ancient worlds. Elective History can be undertaken in addition to the compulsory Stage 5 History courses.

The course work is delivered in a creative manner and will allow students to see history in a completely different way. It is indeed a course that is insightful and will definitely challenge the way historical events are viewed. The course will assist you greatly in your development of historical skills. Students will investigate study options from each of the three key topic areas listed below:

1. History, Heritage and Archaeology
2. Ancient, Medieval and Modern Societies
3. Thematic Studies

100 hours (1 year) Course

Topics include:

- ONE option from each of Topics 1, 2 and 3

200 hours (2 years) Course

Topics include:

- ONE option from each of Topics 1, 2 and 3 and at least TWO other options from any of the topics

Assessment

Students will be assessed through tasks including source analysis, investigations, recreating ancient artefacts, presentations, essays and examinations.

Topic 1: History, Heritage and Archaeology	Topic 2: Ancient, Medieval and Modern Societies	Topic 3: Thematic Studies
<ul style="list-style-type: none">• Archaeological sites• Biography• Family history• Film as history• Heritage and conservation• Historical fiction• Historical reconstructions• History and the media• History websites/online environments• Local history• Museum and/or archives studies• Oral history	<ul style="list-style-type: none">• Africa• The Americas• Asia• Australia• Europe• The Middle East• The Pacific	<ul style="list-style-type: none">• Continuity and diversity of Aboriginal cultures and histories• Economy and society• Children in history• Crime and punishment• Gender in the past• Heroes and villains• Music through history• Power and political unrest• Religious and spiritual beliefs/practices• Slavery• Sport and recreation in history• War and peace• World myths and legends• A school-developed study

Course Description

Engineering is a practical based course which provides opportunities for students to develop knowledge, understanding and skills in relation to engineering and its associated industries.

Core modules develop knowledge and skills in the use of materials, tools and techniques related to structures and mechanisms. These are enhanced and further developed through the study of specialist modules in Control Systems and Alternative Energy.



Students will use a wide variety of materials and processes in the construction of their projects. As with all Industrial Arts subjects student safety is a priority and students are required to wear **shoes with leather uppers** if they wish to study this course. Aprons and other safety equipment are supplied by the faculty.

200 hours (2 years) or 100 hours (1 year) Course

Practical projects will reflect the nature of the Engineering focus area and provide opportunities for students to develop specific knowledge, understanding and skills related to engineering. These may include projects or activities such as:

- Bridge Design, Building and Testing
- Trebuchet Design and Construction
- Solar Powered Vehicles
- Mouse Trap Powered Cars
- Water Jet Powered Cars
- Hydraulic Systems
- Computer Aided Drawing



Assessment

Learning outcomes are assessed through the design and construction of student projects and associated written reports.

Course Description

Metal is primarily a practical based subject that is suitable for both female and male students who express an interest in this field and/or may wish to expand further into a trade related career path after school.

Students will be introduced to and use a variety of machines including MIG welders, metal lathes, milling machines, magna benders and grinders during the construction of their projects.

Students will use a variety of materials and hardware in the construction of their projects.

As with all Industrial Arts subjects, student safety is a priority and **students are required to wear shoes with firm leather uppers** if they wish to partake in this course. All other safety equipment is supplied by the faculty.

100 hours (1 year) Course

Examples of projects undertaken can include

- Candelabras
- G-clamp
- Plumb bob
- Saw horse

200 hours (2 years) Course

Examples of projects undertaken can include

- Mechanics creeper board
- Tack hammer
- Wind vane
- Coffee table

Assessment

In this practical course the majority of learning outcomes are achieved through hands on activities during the construction of metal projects. A project journal is submitted with each practical project. Projects undertaken will enhance a student’s knowledge and skills within the metal, machining and metal fabrication areas.



Course Description

Timber is a practical based course suited to both male and female students who are interested in developing their skills and knowledge of working with timber and the associated industries.



Students will undertake a range of practical projects that will occupy the majority of course time. Practical experiences are used to enhance knowledge and develop skills in designing, producing and evaluating.

As with all Industrial Art subjects student safety is a priority and students are required to wear **shoes with leather uppers** if they wish to study this course. Aprons and other safety equipment are supplied by the faculty.

100 hours (1 year) Course



Projects undertaken in this course may include a bread board, mantle clock, medicine cabinet and side table.

Projects are designed to introduce students to the variety of materials, tools and machines used in the industry, as well as different methods of productions, including joinery methods and wood turning.

200 hours (2 years) Course

Projects undertaken during this course of study are more complex and demanding. They will extend and challenge students' skills and knowledge.



Assessment



Learning outcomes are assessed through the design and construction of student projects. A project journal is completed for each practical project.

Project work could include a utensil tidy, bedside cabinet and a design project of each student's choice.

Students will use a wide variety of materials and hardware in the construction of their projects.

Industrial Technology Building and Construction**Course Description**

This course is offered to female students only and is intended to provide students with opportunities to engage in a diverse range of creative and practical experiences using a variety of technologies widely available in industrial and domestic settings.

Students will develop skills through project-based learning in the design, planning, management and production of practical projects.

Students develop knowledge relating to current and emerging technologies in industrial and domestic settings relating to both work and leisure. They will study the interrelationship of technologies, equipment and materials commonly used in the Building and Construction industry.

Students investigate Work Health and Safety (WHS) matters and related work environments while developing a range of skills that equip them for future learning, potential vocational pathways such as;

- Carpentry
- Tiling
- Plumbing
- Concreting and bricklaying
- Lock Smithing
- Landscaping

**100 hours (1 year) Course**

Projects will reflect the practical nature of the Building and Construction industry and provide opportunities for students to develop specific knowledge, understanding and skills related to building and construction technologies. These may include:

- construction of small structures
- scale models
- elementary repairs and renovations
- development of garden and recreational areas

Assessment

Students are assessed through a variety of practical activities, project folios and reports.

Course Description

Music appeals to students who are creative. Music can take you anywhere – become a rock musician, sound technician, video clip producer, computer music specialist, teacher or administrator. Students wishing to continue with music should take the Music course over 200 hours. Students with a general interest should take the 100 hour course.

In this course students will develop the following skills:

- Higher order thinking
- Problem solving
- Creativity
- Communication
- Team work
- Leadership



200 hours (2 years) or 100 hours (1 year) Course

PERFORMANCE

Learn to play an instrument or sing. Learn to perform professionally for audiences. Improve your music skills. Everybody is expected to participate in performance activities.

COMPOSITION

Learn to write music on the computer and play your own music. Create, compose and arrange different styles of music.

AURAL

Listen to all different kinds of music, and learn to write about the elements of music – Duration, Pitch, Texture, Performing Media and timbre, Dynamics and Expression, Structure

MUSICOLOGY

Learn to read, write and notate music. Learn about different topics: e.g. Popular Music, Music for Film, radio and TV, Australian music, plus more.

Assessment

- Students are assessed in the following 3 areas: 40% Performance, 30% each for listening and composition
- Performance- Solo and Group- singing, or musical instrument
- Composting- writing music
- Aural- responding to music, listening and writing, developing listening skills



Course Description

The Music Theatre elective class is a practical, hands-on course that teaches the "triple threat" skills of singing, dancing, and acting required for Musical Theatre. This class provides training in solo and ensemble performance, focusing on developing technical proficiency in each discipline, understanding character interpretation, and collaborating with other performers. The goal is to equip students with the skills and experience to succeed in the musical theatre industry, often culminating in a live showcase for industry professionals.

In this course students will develop the following skills:

- Higher order thinking
- Problem solving
- Creativity
- Communication
- Team work
- Leadership

**200 hours (2 years) or 100 hours (1 year) Course****SINGING**

Training in both solo and ensemble performance, covering a range of musical theatre repertoire and developing healthy, technically proficient vocal projection.

DANCING

Instruction in various dance styles suitable for musical theatre, including ensemble and individual work.

ACTING

Development of acting techniques for spoken and sung dialogue, focusing on character interpretation and creative response to scripts.

COLLABORATION

Learning to work effectively with other performers and industry professionals in a creative environment.

Assessment

Students are assessed in the following 2 areas: 60% Performance, 20% for Making and 20% Appreciation

- Performance- Solo and Group- Singing, Dancing and Acting
- Making- creating and experimenting through musical and dramatic processes and experiences
- Appreciation- analysing and evaluating how creative choices shape intention and meaning

PHOTOGRAPHIC AND DIGITAL MEDIA

Fee: \$35

Course Description

The Photographic and Digital Media course is designed to provide students with a wide variety of opportunities in photographic techniques and processes.

and artistic approaches to taking great photos and printing your own copies. Exploring the technical aspects of how a camera functions and digital software editing.

In this course students will develop the following skills:

- Higher order thinking
- Problem solving
- Design innovation
- Creativity
- Communication
- Teamwork
- Leadership



100 hours (1 year) Course and 200 hours (2 year) Course

- Learn about photography
- Complete digital photo editing
- Develop artistic intentions through photography
- Understand conceptual photography
- Complete and compile a short film
- Learn both stop motion and film editing
- Act as an artist and fuse digital interfaces
- Design and develop projects using photoshop to edit and enhance images

Assessment

This course is 60% practical and 40% theory.

Students will be assessed on:

- Photographic editing through digital software
- Conceptual photography
- Short film
- Short answer responses
- Self-reflection
- Photographer research

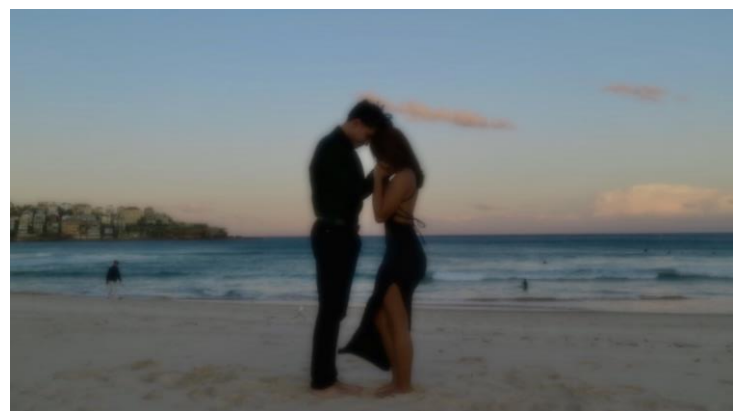
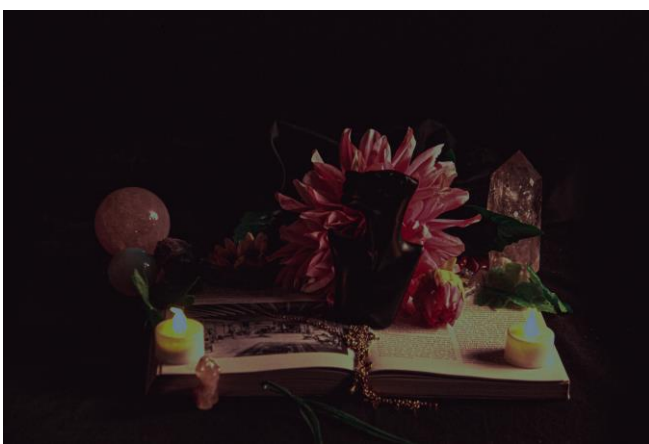

Course Description

Physical Activity and Sports Studies (PASS) is a practical based course for students who are interested in participating in a variety of physical activities & studying issues related to sport. Students will participate in two practical and two theory lessons each timetable cycle. Students will enhance their capacity to participate effectively in physical activity and sport, leading to improved quality of life for themselves and others. Students will also appreciate the enjoyment and challenge of participation in physical activity and sport and value the contributions of physical activity and sport to wellbeing and society.

To do this course you should:

- Enjoy being physically active, as participation in practical activities is compulsory
- Be interested in sport sciences, as you will spend one lesson per week in the classroom
- Be able to work cooperatively in a group and also be capable of independent work
- Have a positive attitude and be ready to learn and try new things

**100 hours (1 year) course covers either Year A or B topics.
200 hours (2 year) course covers both Year A and B topics.**

Year A Theory Topics

Issues in Sport (drugs, violence, gender)

Nutrition

Year A Practical Topics

Gridiron

European Handball

Volleyball

Event Management

Enhancing Performance

Lacrosse

Dodgeball/Spikeball

Year B Theory Topics

The Body Systems

Lifestyle, Leisure and Recreation

Year B Practical Topics

Ultimate Frisbee

Golf

Opportunities and Pathways in Sport Coaching

Badminton

Bocce/Lawn Bowls



Above: Pass Students at Surf School in Manly 2015

Assessment

This course is 50% practical and 50% theory.

Students will be assessed through:

- Practical application of skills
- Written tasks
- Formal examination

Course Description

Students who choose Visual Arts in Years 9 and 10 will receive training in many areas of art practice including drawing, painting, design, ceramics, sculpture and multi-media. Students will learn how to use a wide variety of materials, tools and techniques.

Students will also learn to critically analyse artworks from a range of perspectives. They will learn about a wide range of art practices and the way they have shifted over time, as a result of cultural, political and technological advances.

In this course students will develop the following skills:

- Higher order thinking
- Problem solving
- Design innovation
- Creativity
- Communication
- Team work
- Leadership

200 hours (2 years) or 100 hours (1 year) Course

- Sculpture with found and recycled material
- Manga drawing with digital rendering
- Mixed media painting
- Creating artwork using Text
- Clay sculpture
- Mixed media sculpture
- Skateboard deck digital design
- Scratch foam and etching printmaking

Assessment

This course is 60% practical and 40% theory.

Students will be assessed on:

- Use of Photoshop to design
- Developing skills and understanding in a range of artistic mediums- photography, sculpture, painting drawing
- Historical and cultural analysis of artists- essay writing, case studies, research

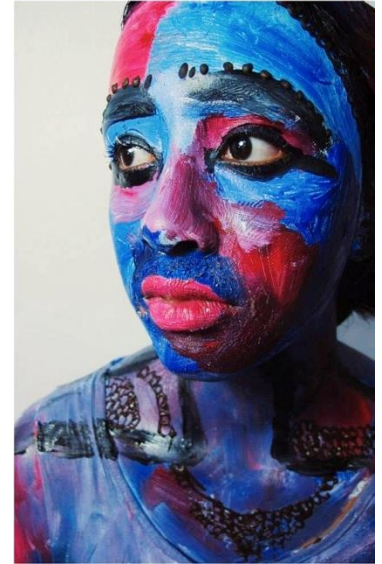

Course Description

The course will let you experience the skills needed to enter the world of advertising, architecture, interior decorating and design, industrial and product design, computer graphics, sign writing, landscaping, packaging, fashion design, illustration and cartooning and a wide range of film and TV careers.

The Visual Design course offers students real world opportunities to develop design solutions and innovative problem solving skills that are highly desired by employers in a wide range of industries.

In this course students will develop the following skills:

- Higher order thinking
- Problem solving
- Design innovation
- Creativity
- Communication
- Team work
- Leadership

Whenever you open a book, magazine or newspaper, turn on the TV, go to a movie, walk through a shopping centre or select a piece of clothing, you encounter the work of visual design and commercial artists.

A commercial or visual design artist determines the appearance of things all around us, including furniture, automobiles, toys, interior design, mobile phones and portable CD players.

This course is designed for you to experience a range of graphic techniques that are used in a wide range of industries and careers.



200 hours (2 years) or 100 hours (1 year) Course

- Write and illustrate children's book
- Collaborative projects with small and large groups- specific design project
- T-shirt design
- Body adornment
- Stage design
- Architecture and interior design
- Working with clients from local businesses and primary schools to meet design briefs.

Assessment

This course is 60% practical and 40% theory.

Students will be assessed on:

- Use of Photoshop to design developing ICT Skills
- Develop skills and understanding of how to de code and visually analyse images
- Historical and cultural analysis of design- essay writing, case studies, research

Notes